



# PICOTE MINI ROLLER

## OPERATION, SAFETY & INSTALLATION MANUAL



### **WARNING**

*These instructions are for your personal safety. Always ensure that you have read and understood these instructions before using the equipment.*

**SAVE THESE INSTRUCTIONS FOR FUTURE REFERENCE.**

# TABLE OF CONTENTS

SAVE ALL WARNINGS AND INSTRUCTIONS FOR FUTURE REFERENCE

TOPIC	PAGE
SAFETY INFORMATION & SYMBOLS	3
AVAILABLE SIZES & POWER SOURCES	4
DESCRIPTION	5
ASSEMBLY & USE	6
MAINTENANCE & ACCESSORIES	10
TRAINING	10
TRANSPORT, FASTENING & DISPOSAL	10
WARRANTY POLICY & PROCEDURE	11

To watch practical demonstration videos, or to download an electronic copy of these Instructions, please visit [www.picotegroup.com](http://www.picotegroup.com). Please note that videos are not intended as a replacement or alternative to this operating and safety manual, but only as an additional learning tool.

# SAFETY INFORMATION

SAVE ALL WARNINGS AND INSTRUCTIONS FOR FUTURE REFERENCE

## WARNING

This section contains important safety information.  
Failure to comply could result in serious injury or death.

### Safety Symbols

Safety symbols are used throughout this manual to draw attention to potential hazards.



**Danger** risk of serious injury, follow instructions.



**Danger** risk of serious injury from moving parts, follow instructions.

### Personal Protective Equipment (PPE)

Always use Personal Protective Equipment including suitable protective clothing, footwear, plus:



Suitable eye protection to protect against injuries and chemicals from irritating eyes.



Suitable heat and cut-resistant gloves to help prevent any hand injuries. Any open injuries or skin irritations should always be covered to avoid contact with sewage, chemicals or dust.



Suitable respirator to prevent any dust or fumes being inhaled or consumed, which could cause occupational asthma or dermatitis.

# TECHNICAL INFORMATION

SAVE ALL WARNINGS AND INSTRUCTIONS FOR FUTURE REFERENCE

## AVAILABLE SIZES & POWER SOURCES

The Picote Mini Roller range has been designed for wetting out of short and medium-size Cured-in-Place (CIPP) liners. Available for the rehabilitation of pipe sizes from DN50 (2") to DN150 (6").

- Select the correct Narrow Liner Holder according to the diameter of the original host pipe.
- The Picote Mini Roller opening gap is set using the adjustment wheel.
- Picote Mini Roller is operated with a power drill.
- The quick locking upper assembly allows the user to lift up or completely remove the upper roller.

Technical Specifications	
Liner Sizes	DN50-150 (2-6")
Speed	Variable: Drill Powered
Weight	7.5 kg (16½ lbs)
Dimensions	400x366x145mm
Product List	
Part Number	Description
2390000000	Picote Mini Roller
2360101050	Liner Holder DN50 (2") Narrow
2360101075	Liner Holder DN70 (3") Narrow
2360101100	Liner Holder DN100 (4") Narrow
2360101150	Liner Holder DN150 (6") Narrow

# DESCRIPTION & GENERAL INFORMATION

SAVE ALL WARNINGS AND INSTRUCTIONS FOR FUTURE REFERENCE

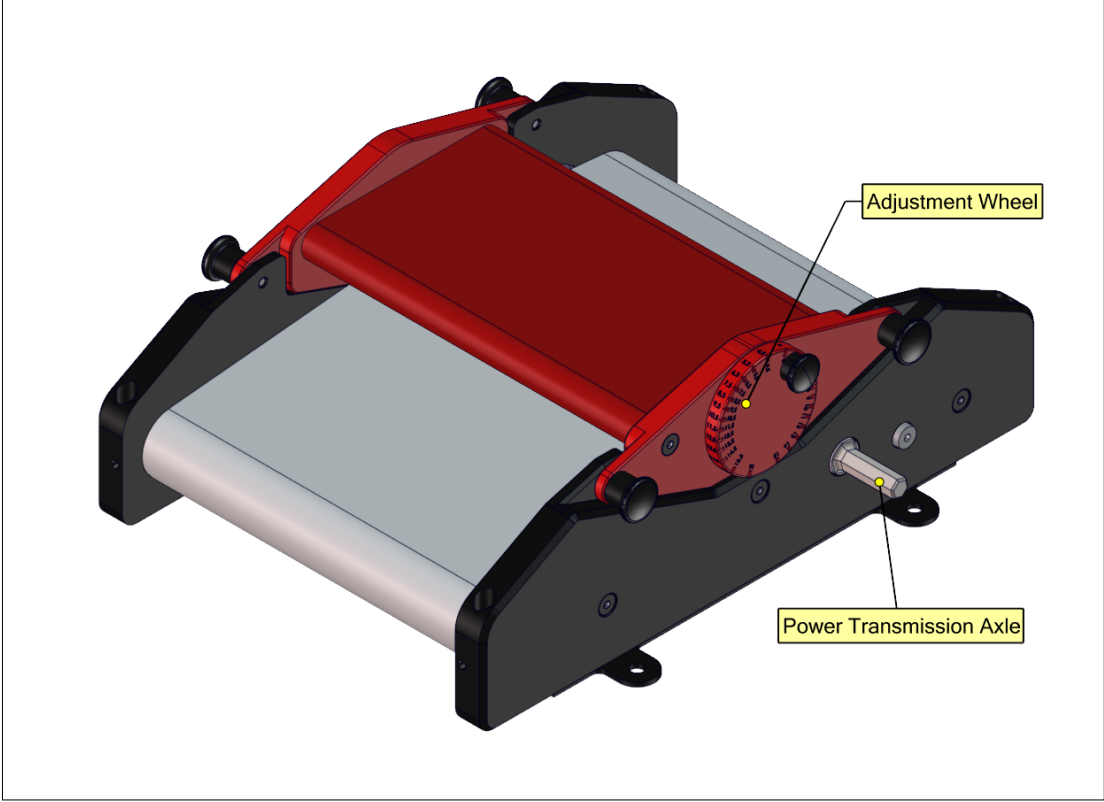
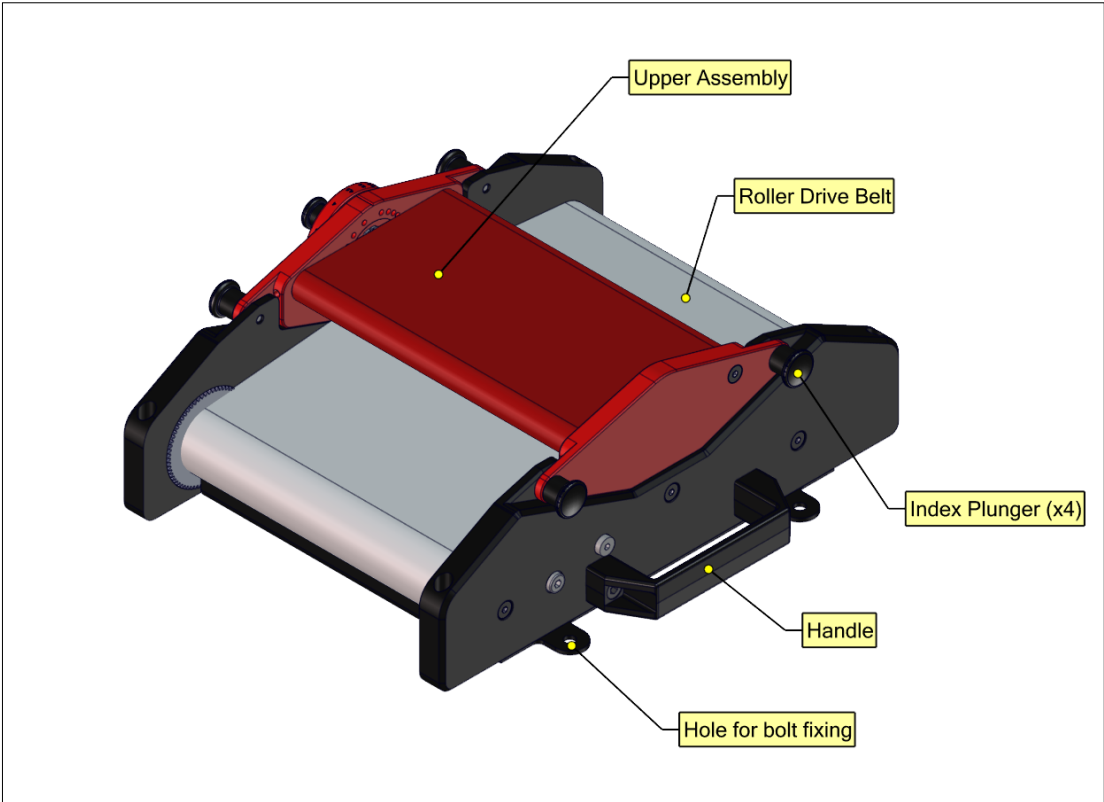

# WETTING OUT THE LINER

SAVE ALL WARNINGS AND INSTRUCTIONS FOR FUTURE REFERENCE



A properly wet out liner is a key for a successful installation. The use of the Mini Roller ensures that the resin is evenly distributed throughout. The Picote Mini Roller has been developed to impregnate short liners. It is lightweight, transportable and easily powered by any power drill.

Use Narrow Liner Holders to give you extra pair of hands.

See accessories list for available Narrow Liner Holders.

**Step 1.** Select the correct size Narrow Liner Holder and push it inside locking holes of the Picote Mini Roller.

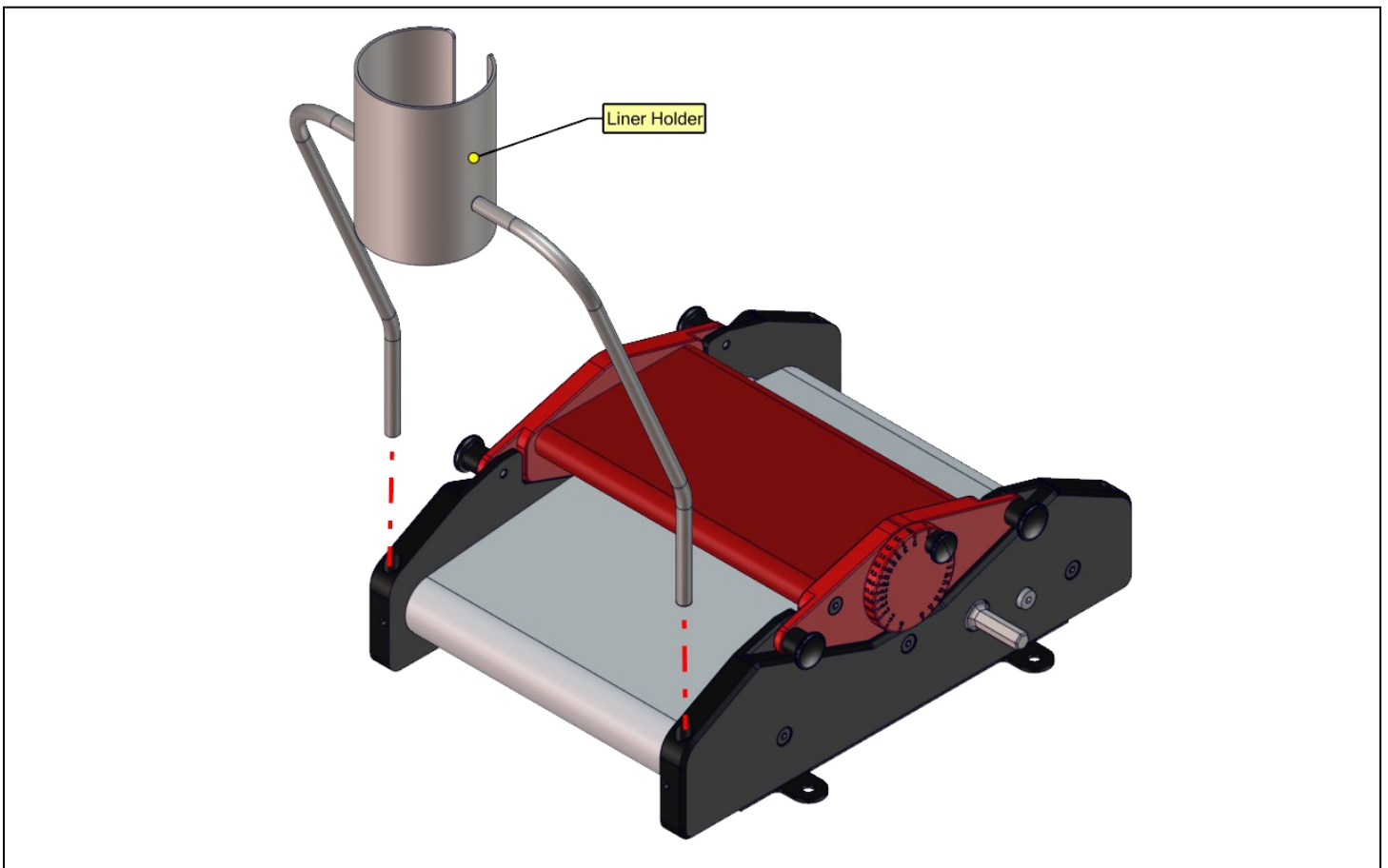

# WETTING OUT THE LINER

SAVE ALL WARNINGS AND INSTRUCTIONS FOR FUTURE REFERENCE



**Step 2.** Attach the power drill onto the power transmission axle. Place liner into Mini Roller.

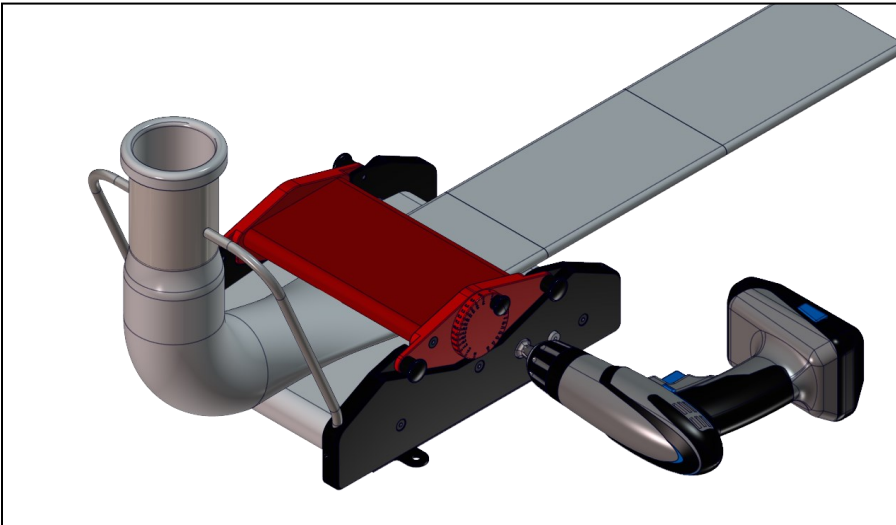

**Step 3.** Dispense the resin in accordance with the liner manufacturers instructions. To push the bulk resin through the Mini Roller, first open the two Index Plungers (showed below) and lift up the Upper Roller.

Note: To achieve full impregnation you should always use a vacuum pump.

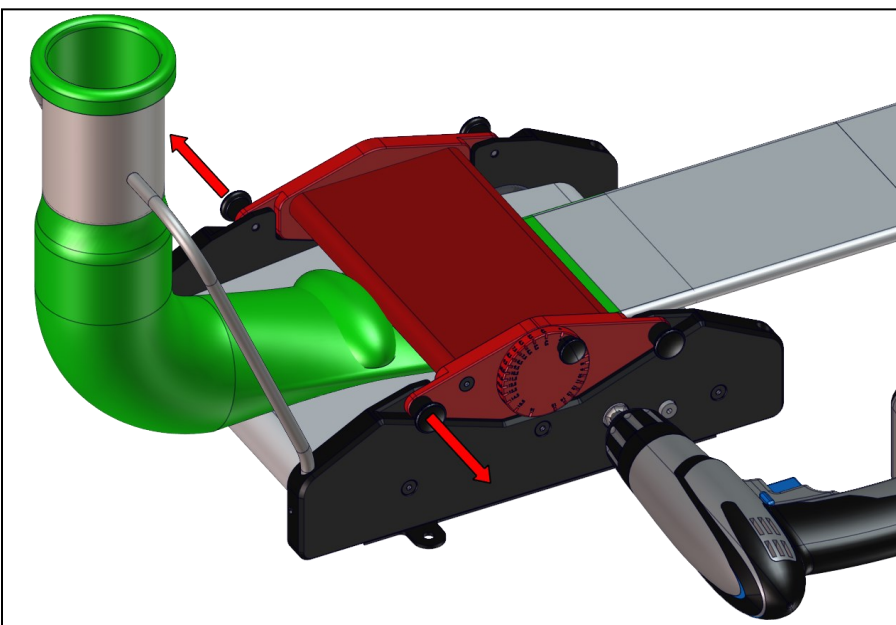

# WETTING OUT THE LINER

SAVE ALL WARNINGS AND INSTRUCTIONS FOR FUTURE REFERENCE



**Step 4.** Once the Upper Roller is opened, move the resin lump through the opening.

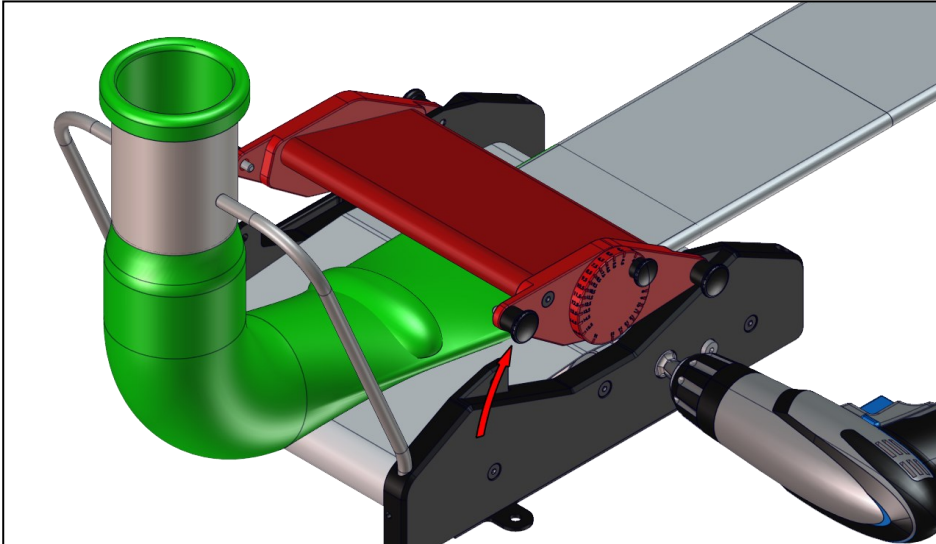

**Step 5.** Adjust the opening by turning the adjustment wheel if needed.

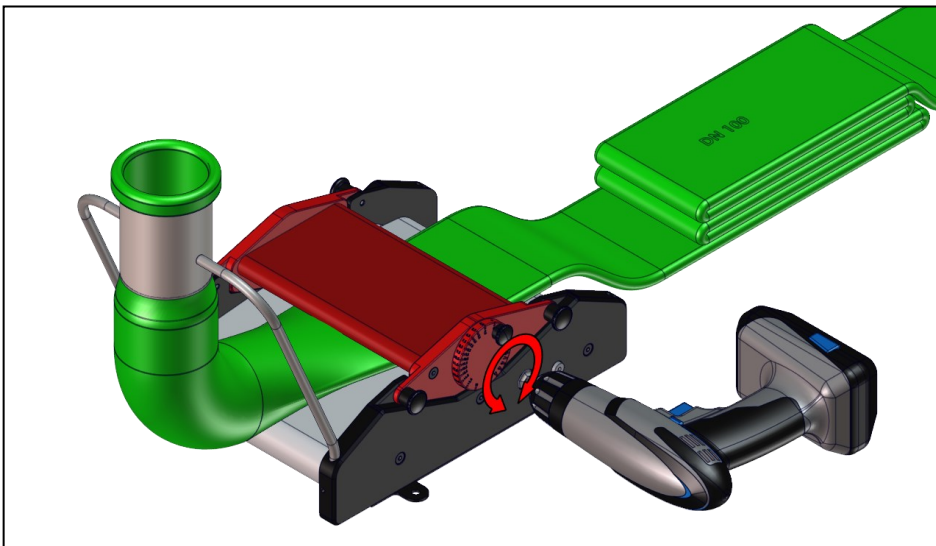



# USING THE MINI ROLLER

## SAVE ALL WARNINGS AND INSTRUCTIONS FOR FUTURE REFERENCE

### Before Starting

Check the diameter of the host pipe and measure its length before selecting the correct size liner. Measure out the correct length of liner needed and cut.

Check the condition of the Picote Mini Roller so that the work can be done safely and without unexpected interruptions:

- Visually inspect the Mini Roller for any signs of damages.
- If required fix the Picote Mini Roller to a table.
- Equip the power drill with charged battery.
- Test that Mini Roller works normally when powered.
- Choose desired speed from the power drill.
- Test that the Drive Belt is tightened. Correct if needed.
- According to the liner manufacturers instruction, adjust the gap in between rollers using the adjustment wheel to the correct thickness.
- Install the correct size Liner Holder to the Mini Roller.
- Add the liner to the Liner Holder and connect the vacuum pump.
- Prepare the resin.

### During Use

Carefully pour the prepared resin inside the liner. Push the resin lump through the Picote Mini Roller. Open Index Plungers holding the Upper Assembly if needed to make this step easier. Vacuum out the air in the liner. Power up the Mini Roller and carefully spread the resin throughout the liner to fully wet out it. Adjust the roller gap when needed. Change the position of the liner to ensure there are not any dry places left. Be careful not to suck the resin into the vacuum pump.

### After Use

When the liner has been successfully impregnated, take it out from the Picote Mini Roller and continue preparing it for installation. When working in warm locations, use ice or fridge to lower the resin temperature. Colder resin gives more working time before curing process begins. Clean any spilt resin from the Mini Roller before it cures.

## RECOMMENDATIONS

- **Evenly impregnate the liner with the resin.**
- **Keep Picote Mini Roller clean.**
- **Control the speed of the Mini Roller during the impregnation process and adjust the gap in between rollers when required.**
- **Always follow manufacturer recommendations when wetting the liner.**

# MAINTENANCE

## SAVE ALL WARNINGS AND INSTRUCTIONS FOR FUTURE REFERENCE

### CARING FOR THE PICOTE MINI ROLLER:

- Picote Mini Roller should be maintained regularly.
- Monthly add a few drops of oil to the power transmission parts (gear wheels).
- Regularly check and tighten the Drive Belt.
- Visually inspect the machine for any signs of damage and replace any damaged parts immediately.

### Cleaning:

Easiest way to keep the Picote Mini Roller operational is to keep it clean. Wipe away any drops of resin from the machine while still wet. Immediately replace broken parts with Picote Original replacement parts.

## PICOTE MINI ROLLER

2390000000	Picote Mini Roller
------------	--------------------

## ACCESSORIES

2360101050	Liner Holder DN50 Narrow
2360101075	Liner Holder DN75 Narrow
2360101100	Liner Holder DN100 Narrow
2360101150	Liner Holder DN150 Narrow

Please contact your reseller for more information.

## TRAINING

For information about product training and support contact Picote Solutions or your authorized Picote reseller.

## TRANSPORT & FASTENING

Always fasten the Picote Mini Roller when it is transported in a vehicle, to avoid damage to the vehicle or other equipment. The Mini Roller can be fixed to vehicle surface to provide stable working place and added safety during transport.

## DISPOSAL

Picote Mini Roller has been designed to be recyclable. Separate metallic and plastic components and dispose of separately according to local waste regulation.

# WARRANTY POLICY AND PROCEDURE

## SAVE ALL WARNINGS AND INSTRUCTIONS FOR FUTURE REFERENCE

### Limited Warranty:

Picote warrants to the original End User that the Product purchased by such End User will operate in accordance with, and substantially conform to their published specifications when shipped or otherwise delivered to the End User and for a period of one (1) year, except electric motors for which the warranty period shall be six (6) months, provided, however, that Picote does not warrant any claim or damage under this Warranty if such claim or damage results from:

1. Consumable parts or normal wear and tear resulting from use of the Products,
2. Product overload or overheated motor,
3. Regular periodic maintenance of Products,
4. Misuse, neglect, or improper installation or maintenance of the Products, or use of Products not for their intended purpose,
5. Products that have been altered, modified, repaired, opened or tampered with by anyone other than Picote or an authorized Picote Service Centre, or unsuitable or unauthorized spare parts, accessories or third party products when using the Products or;
6. the use of the Products not in compliance with their respective Documentation, user manuals, safety and maintenance instructions, and any usage restrictions contained therein, or
7. accident, fire, power failure, power surge, or other hazard.

Otherwise, the Products are sold AS IS. End User is responsible for using the Products within their specifications and instructions as contained in the Documentation.

**EXCEPT AS SPECIFIED IN THIS WARRANTY, ALL EXPRESS OR IMPLIED CONDITIONS, REPRESENTATIONS, AND WARRANTIES INCLUDING, WITHOUT LIMITATION, ANY IMPLIED WARRANTY OR CONDITION OF MERCHANTABILITY, FITNESS FOR A PARTICULAR PURPOSE, NON INFRINGEMENT, SATISFACTORY QUALITY OR ARISING FROM A COURSE OF DEALING, LAW, USAGE, OR TRADE PRACTICE, ARE HEREBY EXCLUDED TO THE EXTENT ALLOWED BY APPLICABLE LAW. TO THE EXTENT AN IMPLIED WARRANTY CANNOT BE EXCLUDED, SUCH WARRANTY IS LIMITED IN DURATION TO THE WARRANTY PERIOD. BECAUSE SOME STATES OR JURISDICTIONS DO NOT ALLOW LIMITATIONS ON HOW LONG AN IMPLIED WARRANTY LASTS, THE ABOVE LIMITATION MAY NOT APPLY. This disclaimer and exclusion shall apply even if the express warranty set forth above fails of its essential purpose.**



**Please Contact:**  
Your Reseller / Salesperson or Picote

**[www.picotegroup.com](http://www.picotegroup.com)**



**International Offices**

Finland. United Kingdom. USA.

**Technical Support**

[support@picotesolutions.com](mailto:support@picotesolutions.com)

**Production & R&D**

Pienteollisuustie 24  
06450 Porvoo, Finland  
[support@picotesolutions.com](mailto:support@picotesolutions.com)

**E-Learning**

Free Connection Collar 2.0 - Equipment  
101 E-learning course is available at:  
[www.picoteinstitute.com](http://www.picoteinstitute.com)

**Claims**

[claims@picotesolutions.com](mailto:claims@picotesolutions.com)

**Authorised Resellers:**

**[www.picotegroup.com/resellers](http://www.picotegroup.com/resellers)**